

NPSH of Pump Units and Pumping Systems

The NPSH (Net Positive Suction Head) is related to the problem of cavitation; besides head, capacity, and power demand, it represents one of the most important operational factors of a pump. There must be distinguished between NPSH of the plant ($NPSH_{available}$) and NPSH of the pump unit ($NPSH_{required}$). By simple comparison between $NPSH_{av.}$ and $NPSH_{req.}$ one can judge whether the operational safety of any pump selected for the respective system is ensured or not. The condition for operation without cavitation is:

$$NPSH_{av.} > NPSH_{req.} \quad (1)$$

The above requirement must be met over the entire permissible operating range of a pumping system. This will be the case only if $NPSH_{av.}$ [m] exceeds $NPSH_{req.}$ [m] by a certain safety allowance, usually rated at 0.5 m.

Example:

$NPSH_{av.}$ is assumed to be 3 m and the pump selected acc. to capacity and head to have in its operating point an $NPSH_{req.}$ of 4 m, reference to requirement (1) shows that the system cannot be expected to give satisfactory operation.

If condition (1) is not met, i. e., if $NPSH_{av.}$ is lower than $NPSH_{req.}$, the pump operates under cavitating conditions which means that the liquid pumped vaporizes within the pump which causes:

- a) breakdown of suction column and head,
- b) loud noise and heavy vibration leading to erosion or pitting and possibly destruction of the impellers.

In HERMETIC-pumps, there are two additional points i. e.:

- c) breakdown of the partial flow through the motor section resulting in reduced bearings lubrication,
- d) insufficient motor heat removal as well as upset of the hydraulic axial thrust balance.

Permanent cavitation conditions will definitely lead to failure of the HERMETIC-pump.

NPSH of Pump

The value of $NPSH_{req.}$ depends on the pump data only, and not on the system data; it changes for any pump with flow quantity and speed, being always positive. The $NPSH_{req.}$ is independent of the kind of liquid pumped. In the characteristic curves of any pump, the NPSH values indicated are based on measurements carried out with cold water as pumping liquid. They have been established in a NPSH test plant designed just for that purpose, and they can be checked at any time. The $NPSH_{req.}$ defines the suction capability of a pump at a determined point of operation:

the lower the $NPSH_{req.}$, the greater the suction capability.

Low $NPSH_{req.}$ values can be obtained by suitable pump design. They are of particular importance when pumping near-boiling liquids (liquefied gases).

NPSH of System

The $NPSH_{av.}$ is the total head available at the suction nozzle of the pump above the vapour pressure of the liquid pumped. That term comprises in one single value all individual data of the plant. For pump selection the manufacturer must only know the $NPSH_{av.}$ to be able to guarantee trouble-free operation of the pump system.

The individual plant data comprised in the $NPSH_{av.}$ are as follows:

- the **geodetical suction lift s_l [m]**
Which is the vertical distance between suction level and pump center line. *)
- the **geodetical suction head s_h [m]**
Which is the vertical distance between suction tank level and pump center line.
- the **vapour pressure vp [bar abs.] of the fluid pumped**
The vapour pressure of a liquid at a given temperature (t) is the pressure which causes the liquid to boil when applied on its surface. (example: Water boils at 20 °C in a partial vacuum of 0.023 bar abs.)
- the **gas pressure gp [bar abs.] on the suction-side liquid surface**
The knowledge of that pressure is of particular importance. If the suction tank is open, the gas pressure corresponds to the atmospheric pressure ($gp = 1$ bar abs.). In chemical plants, closed tanks are mostly employed under pressures or partial vacuums differing from the atmospheric pressure (pressure or vacuum systems). If the liquid in the suction vessel is at its boiling point, the vapour pressure (vp) relating to it at the temperature (t) prevails above the liquid surface.
- **Density ρ [kg/m³] of the liquid pumped**
- **Acceleration of the fall $g = 9.81$ m/s²**
- **Suction line head loss s_f [m]**
That is the head loss in pipes and valves on the suction side due to friction. Quite frequently, estimated values are used. In critical cases, calculation can be based on individual resistances of pipes, bends, valves etc. The calculation should be made for the maximum flow quantity to be expected.

*) Operation under suction lift conditions is only possible with self-priming pumps. When using normal-suction pumps, suitable measures (e. g. by incorporating a non-return valve) must be taken to ensure that suction line and pump can never lose prime.

With the mentioned plant data, the $NPSH_{av.}$ can be calculated acc. to the following formulas:

For operation under flooded suction conditions

$$NPSH_{av.} = 10^5 \frac{(gp - vp)}{\rho \cdot g} + s_h - s_f$$

For operation under suction lift conditions

$$NPSH_{av.} = 10^5 \frac{(gp - vp)}{\rho \cdot g} - s_l - s_f$$

(2)

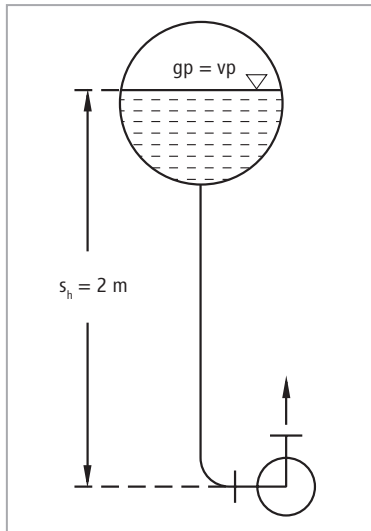

Example 1:

Liquid ammonia shall be pumped from a closed tank at a temperature of 5 °C. The ammonia has reached its boiling point so that the gas pressure in the tank equals the vapour pressure of the liquid ($gp = vp$). Therefore, the expression in brackets of Formula No. 2 becomes zero. If the suction head $s_h >$ is 2 m and the suction line friction loss $s_f = 0.5$ m, the result of Formula No. 2 (operation under flooded suction conditions) will be: $NPSH_{av.} = s_h - s_f = 2.0 - 0.5 = 1.5$ m

Consequently, in order to meet requirement (1), a pump with $NPSH_{req.} = 1$ m (providing for 0.5 m safety allowance) or less must be selected.

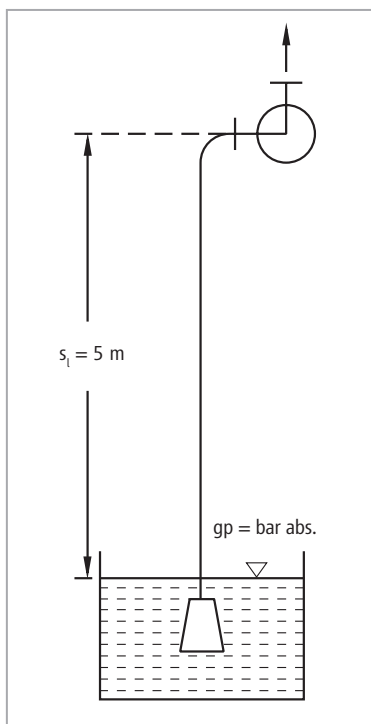

Example 2:

Liquid octane shall be drawn from an open suction vessel at 20 °C. The geodetical suction lift s_l is 5 m, on the suction surface there is an atmospheric pressure of $gp = 1$ bar abs. Vapour pressure and density at 20 °C are $vp = 0.013$ bar abs. and $\rho = 700$ kg/m³. The suction line friction loss incl. non-return valve is estimated at $s_f = 1$ m. With those plant data, Formula No. 2 (operation under suction lift conditions) results in:

$$NPSH_{av.} = 10^5 \frac{(1.0 - 0.013)}{700 \cdot 9.81} - 5.0 - 1.0 = 8.4 \text{ m.}$$

Consequently, any normal-suction or self-priming pump with an $NPSH_{req.}$ of 7.9 m or lower can be used in that plant.

Pumping of near-boiling liquids

From Formula No. 2 it becomes obvious that the difference between the gas pressure (gp) in the suction vessel and the vapour pressure (vp) of the liquid pumped has a decisive influence on the value of $NPSH_{av}$. Critical plant conditions with regard to cavitation are always those where $gp \sim vp$. As a rule, in such cases only operation under flooded suction conditions is possible. The value of $NPSH_{av}$ is about equal to the difference between suction head and suction-side friction losses. If the suction head is not sufficient, in many cases there is the possibility of increasing the $NPSH_{av}$ by raising the pressure (gp) in the suction vessel (nitrogen cushion or similar) in order to meet the condition of $NPSH_{av} > NPSH_{req}$ for cavitation-free running.

Sometimes an increase of the pressure (gp) is not conveniently feasible e. g. when handling liquids which shall be kept at a constant temperature for cooling (ammonia, liquid nitrogen etc.). In those cases, the suction-side friction losses (s_p) should be kept as low and the suction head (s_n) as high as any possible by suitable system design and sizing.

In applications requiring liquefied gases to be drawn from tanks subject to major temperature fluctuations, special care must be taken and the pump manufacturer's advice should be requested if and as considered desirable.



HERMETIC-Pumpen GmbH
Gewerbstrasse 51 · D-79194 Gundelfingen
phone +49-761-5830-0 · fax +49-761-5830-280
hermetic@lederle-hermetic.com
<http://www.lederle-hermetic.com>