

HERMETIC-Pumps in Refrigeration Plants

Due to their construction, HERMETIC canned motor pumps are particularly suited for use in refrigeration plants. They are completely closed and require no maintenance. Figure 1 shows the simplified scheme of a large refrigeration plant. The characteristic of this plant is that the refrigerant flows through a central fluid separator and is then conveyed to the evaporators. The resulting vapour and the supernatant (surplus) fluid return back to the separator. Compressor, condenser and flow control are incorporated in a secondary circuit.

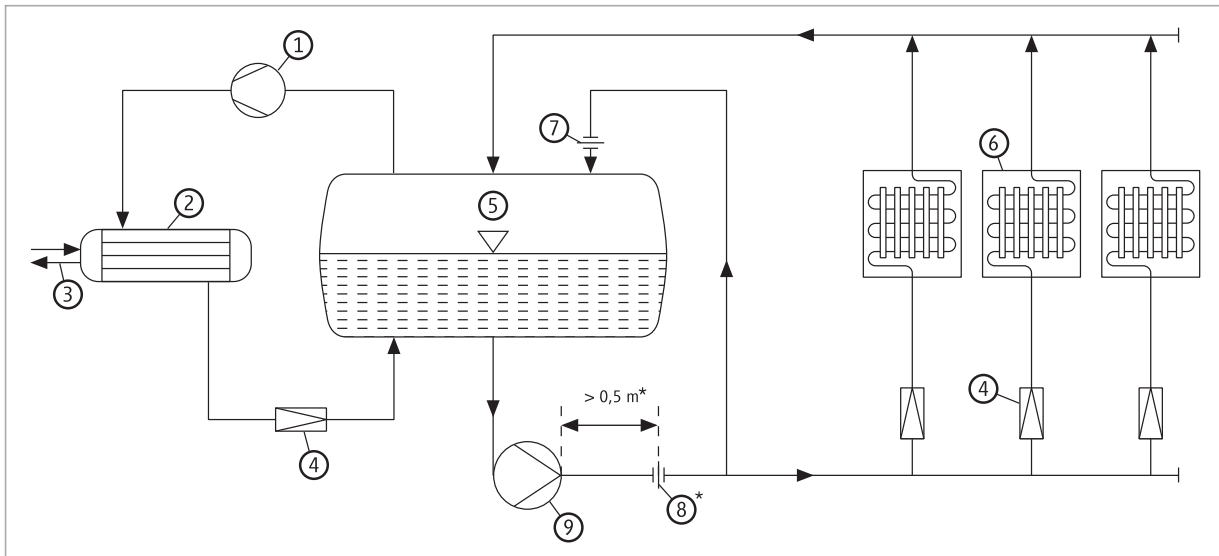

Fig. 1

Refrigeration plant

- | | | | |
|-----------------|----------------------|----------------------|--|
| 1 Compressor | 4 Flow control valve | 7 Q_{min} -Orifice | * not applicable with the installation |
| 2 Condenser | 5 Separator | 8 Q_{max} -Orifice | of a constant flow regulator |
| 3 Cooling water | 6 Evaporator | 9 HERMETIC-pump | |

Design and Installation

Satisfactory operation of HERMETIC-pumps in refrigeration plants depends on correct installation and operation.

The following points must be observed:

1. observance of the necessary minimum suction head to avoid cavitation,
2. operation within the permissible range, between minimum (Q_{min}) and maximum (Q_{max}) capacity,
3. suitable automatic venting of the pump,
4. avoidance of sudden lowering of system pressure or temperature.

If the above points are not carefully observed, dry running may occur and bearing wear and inadequate cooling of the motor will result. It is possible that eventually motor windings will burn out.

ATTENTION: HERMETIC-pumps should never run dry!

Cavitation is not permissible.

The transfer flow [Q] of the HERMETIC-pump depends on the refrigerating capacity of the particular plant.

The discharge head [H] of the pumps depends on the geodetic level of the evaporator, its friction loss and the resistance of pipes, valves, bends, etc.

Recommendations for Installation

1. Refrigerants are liquefied gases which are boiling. To avoid cavitation, a minimum suction head (e_{Min}) is required: (please see HERMETIC-Information „NPSH of pump units and pumping systems“).

$$e_{Min} (m) = NPSH_{req.} (m) + \text{suction line friction loss (m)} + \text{safety margin (m)*} \quad (*\text{usually } 0.5 \text{ m})$$

As refrigeration plants often have only very low suction heads, HERMETIC-pumps are designed to have very low NPSH requirements. However, these machines can only be properly utilised when suction line friction losses are kept to a minimum.

2. The sizing and design of the suction line is of great importance. To ensure trouble-free operation of the pumps, each pump should be provided with a separate suction line. If two pumps are operated in parallel, one suction line will be sufficient (on condition that one pump is a stand-by pump). The suction line should be short, well insulated and fitted with a steady slope to the pump. The recommended flow rate in the suction line should be max. 0.3 – 0.5 m/sec. to give optimum operating conditions.

The suction line must lead as directly as possible to the separator, i.e. without horizontal lines, to ensure that the gas evolving within the suction line or pump can flow to the separator in reverse to the liquid flow. Baffle plates should be installed at the accumulator outlet or before the pump suction line to eliminate vortex formation. It is recommended to install a ball valve with free passage in the suction line. A suction filter is not advisable.

To avoid particles damaging the pump slide bearings, HERMETIC refrigerant pumps incorporate an integral self-cleaning filter.

3. For satisfactory operation of HERMETIC-pumps in refrigerating plants, the pumps must be used within the permissible flow range (pls. see Fig. 2).

Minimum flow is required for:

- a) sufficient cooling of canned motor,
- b) prevention of vaporising inside the pump (dry running of the slide bearings),
- c) avoidance of cavitation in the partial-load operational range of the pump.

Maximum flow is limited by:

- a) motor power rating,
- b) available suction head; NPSH requirement increases with increasing flow,
- c) need to maintain sufficient pressure in the motor to avoid vaporisation of the liquid.

Safety measures:

Q_{min} ensured by Q_{min} -Orifice

Q_{max} ensured by Q_{max} -Orifice or differential pressure switch

$$\Delta p \text{ (bar)} = \frac{H_2 \text{ (m. l. c.)} \times \rho \text{ (kg/m}^3\text{)}}{10^4}$$

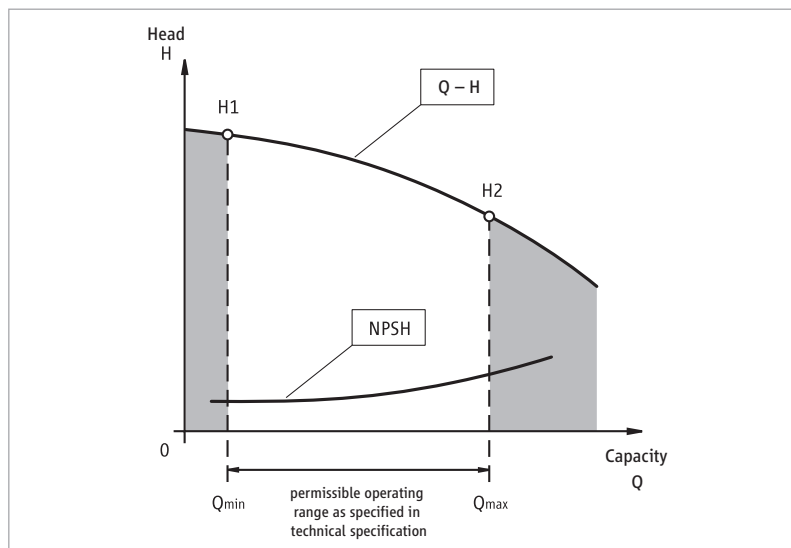

Fig. 2

Operation within the required minimum and permissible maximum flow rate can be ensured by the use of a by-pass or suitable Q_{\min} and Q_{\max} -orifices (pls. see Fig. 3). Instead of the Q_{\max} -orifice, a differential pressure switch can be used to stop the pump if the discharge head becomes lower than the minimum permissible discharge pressure equivalent to Q_{\max} . Time delay max. 10 sec.

ATTENTION:

Any shut-off devices in the by-pass line must always remain open (remove handwheel).

The Q_{\max} -orifice should be installed at least 0.5 m after the discharge nozzle to avoid repercussions on the pump; the Q_{\min} -orifice has to be mounted directly on the separator to avoid two-phase flow.

4. During standstill, the by-pass is used as a vent line. The pump should not be started unless it is primed with liquid refrigerant. During first priming or re-starting, all parts of the pump should be in thermal equilibrium with the suction vessel. When using non-return valves at the pump discharge, note that the by-pass line must be installed before the non-return valve, to permit automatic venting (Fig. 3).

ATTENTION: No check valves should be used in the by-pass line.

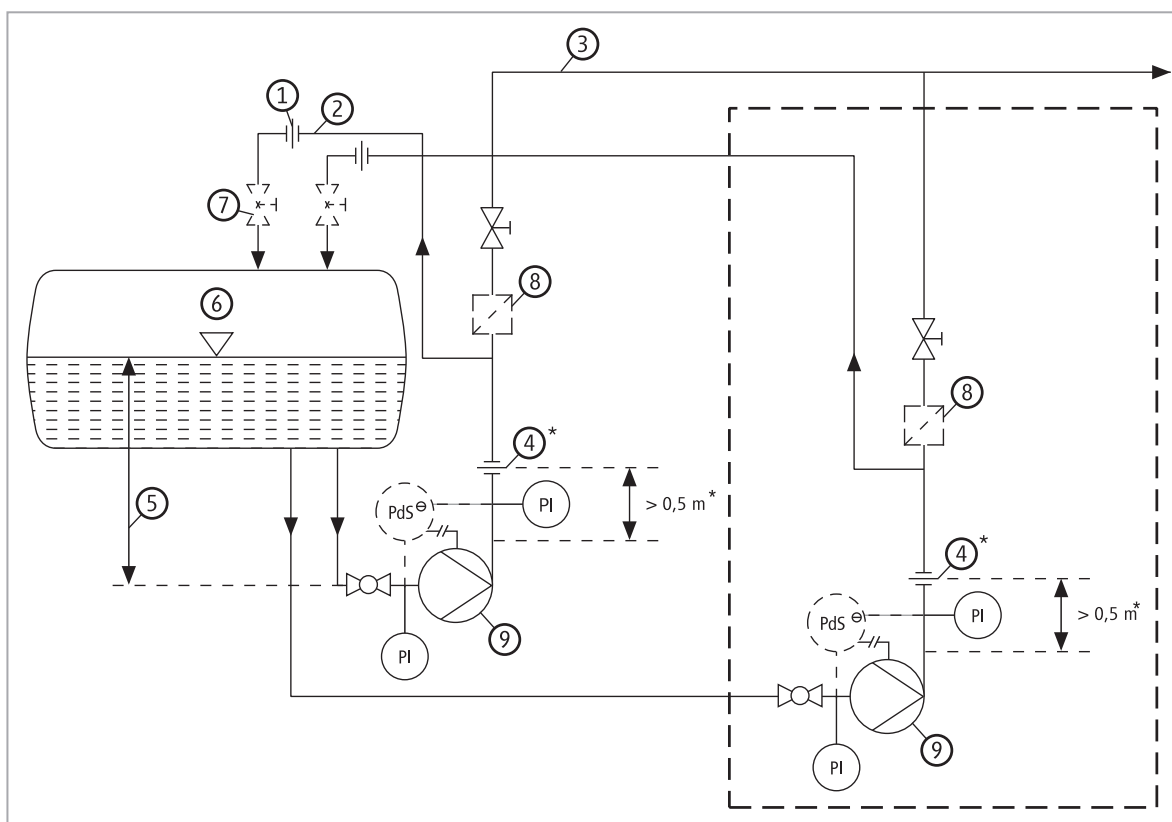

Fig. 3

Automatic venting of the pumps (single pump – parallel pumps)

- | | |
|--|---|
| 1 Q_{\min} -Orifice (directly in front of check valve/separator) | 7 Shut-off valve (directly in front of suction vessel/separator) |
| 2 By-Pass/venting | 8 Check valve |
| 3 Consumer | 9 HERMETIC-pump |
| 4 Q_{\max} -Orifice | |
| 5 Suction head | * not applicable with the installation of a constant flow regulator |
| 6 Separator | |

5. Important changes in temperature and pressure may result in the generation of vapour bubbles caused by the releasing liquid heat which might cause a falling-off in capacity of HERMETIC-pumps (cavitation). The max. admissible pressure down speed depends on the available suction lift, as well as on the staying time of the refrigerant in the suction line, i.e. on the flow speed in the suction line. A fall of pressure always occurs when evaporators have been stopped or when compressor power increases. Thanks to a sensitive regulation of compressor high pressure down speeds may be prevented as far as possible. The most favourable velocity of the liquid in the suction line should be approx. 0.3 – 0.5 m/sec.
6. Low suction heads or high flow rates may result in gas eddies in the suction vessel. This also leads to a considerable decrease in the pump efficiency. Consequently baffle plates should be mounted at the entry of the suction line or a raft should be used to cover the liquid surface.
7. To avoid vaporisation of the liquid by heat from the motor, HERMETIC-pumps in refrigerating plants can only be used up to a restricted maximum operating temperature (pls. see technical specification).
8. When two or more pumps in parallel operation serve a common discharge line (Fig. 3), a separate by-pass line with Q_{\min} -orifice must be provided for each pump unit. This is to remove the gas which arises during standstill of the pump. With this arrangement, the minimum flow is assured and does not depend on the differential head. If one pump is used as a stand-by pump, non-return valves have to be mounted in the discharge line to avoid back-flow from operating to stand-by pump. The stand-by pump should be maintained full of liquid so as to be available for operation immediately. The by-passes enable a switch-over from one pump to the other or a connection of a second pump without operation of shut-off valves.
9. Great quantities of refrigerant oil must not be allowed to accumulate in the pump. At low temperature, the high viscosity might cause problems when starting the pump. If necessary, the system must be provided with suitable oil separators.
10. The canned motor must be protected by a motor protective switch.



HERMETIC-Pumpen GmbH
Gewerbstrasse 51 · D-79194 Gundelfingen
phone +49-761-5830-0 · fax +49-761-5830-280
hermetic@lederle-hermetic.com
<http://www.lederle-hermetic.com>